

(No Model.)

5 Sheets—Sheet 1.

# A. MATTIJETZ, FEED CUTTER.

No. 602,345.

Patented Apr. 12, 1898.

*Fig. I.*

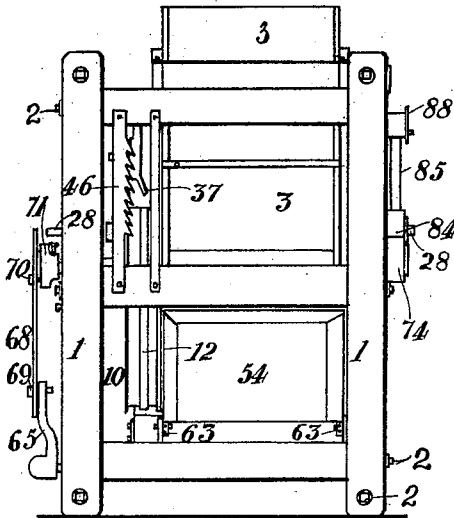

*Fig. II.*

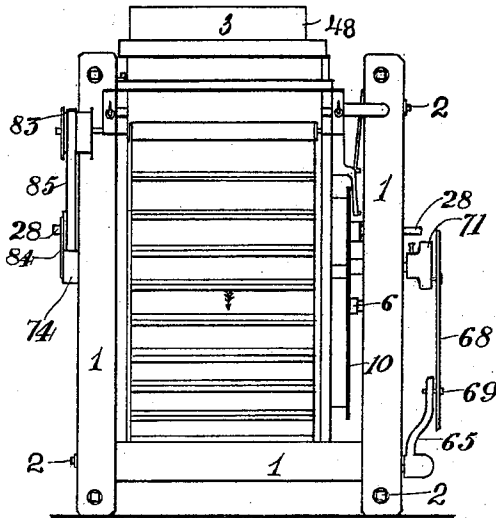

*Fig. III.*

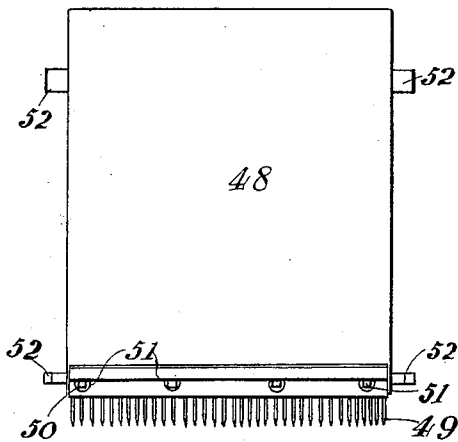

*Fig. IV.*

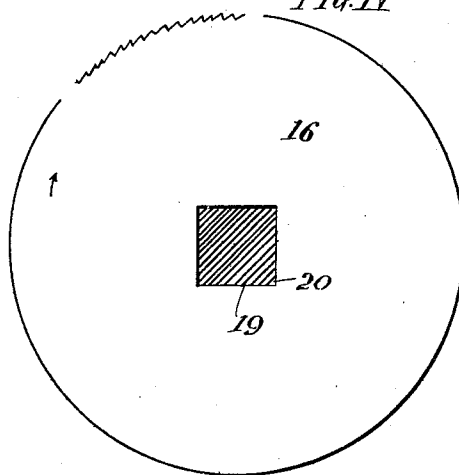

Witnesses:  
*Robt. Train*  
*A. W. Wagner*

Inventor:  
*Andreas Mattijetz*  
 by *Amigh B. Pray*  
 Attorneys.

A. MATTIJETZ.  
FEED CUTTER.

No. 602,345.

Patented Apr. 12, 1898.

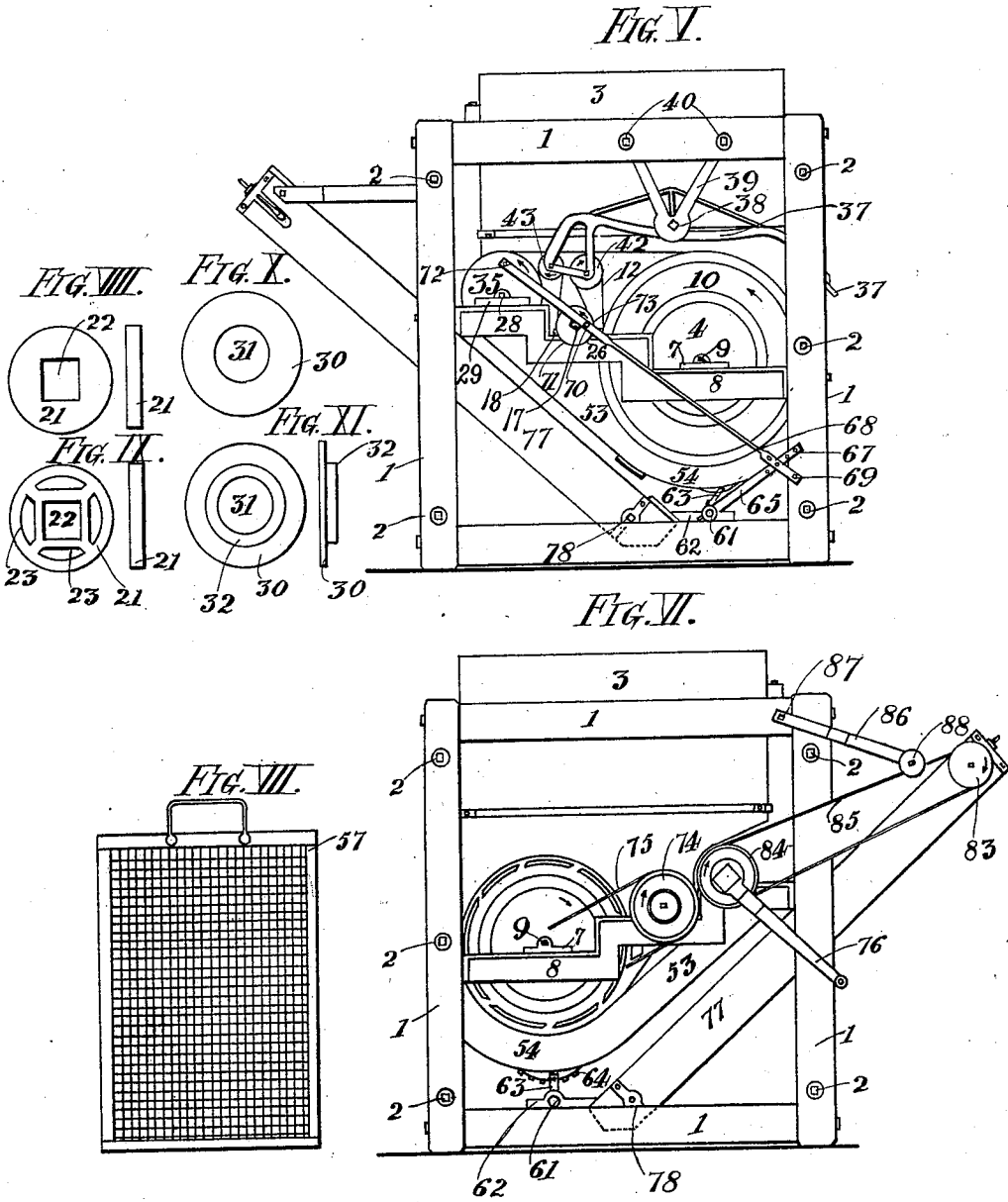

Witnesses:  
 Robt. Train  
 A. W. Wagner

by

Inventor.  
 Andreas Mattijetz.  
 Knight Bros.  
 Attorneys.

# A. MATTIJETZ. FEED CUTTER.

No. 602,345.

Patented Apr. 12, 1898.

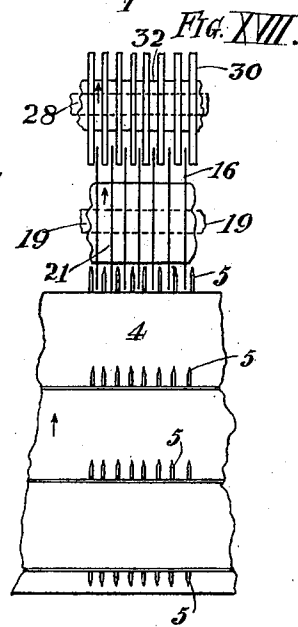
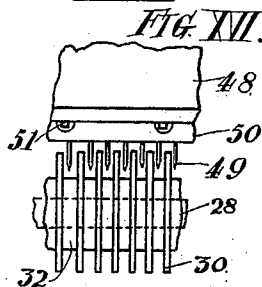
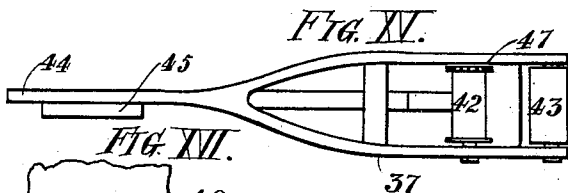
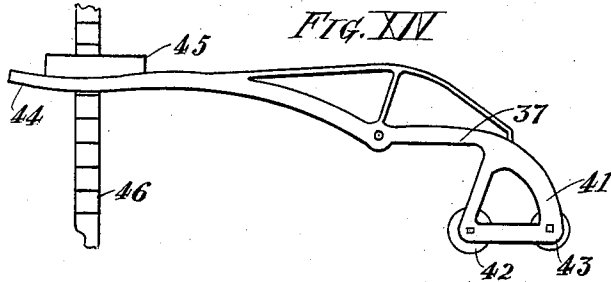
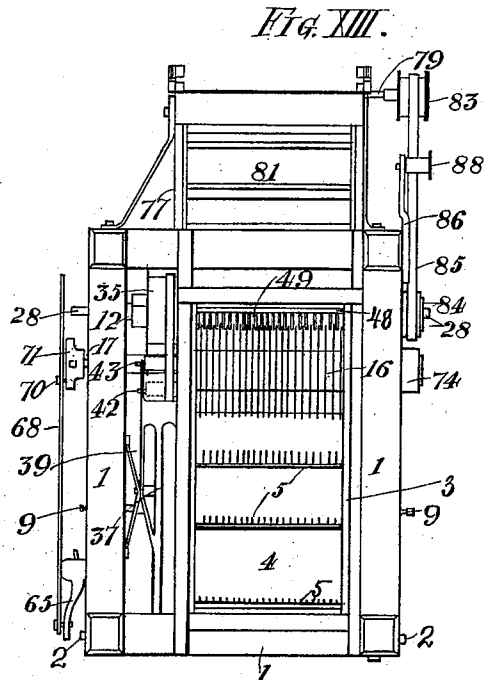
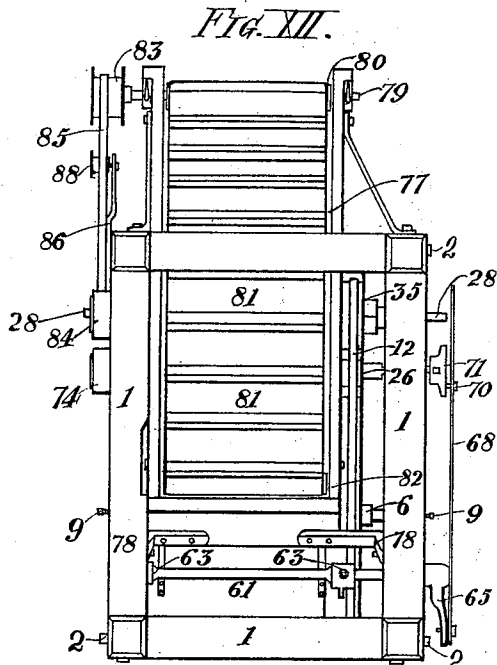

Witnesses:  
*Robt. Train*  
*A. M. Wagner*

Inventor:  
*Andreas Mattijetz*  
 by *Amogh Bros.*  
 Attorneys.

A. MATTIJETZ.  
FEED CUTTER.

No. 602,345.

Patented Apr. 12, 1898.

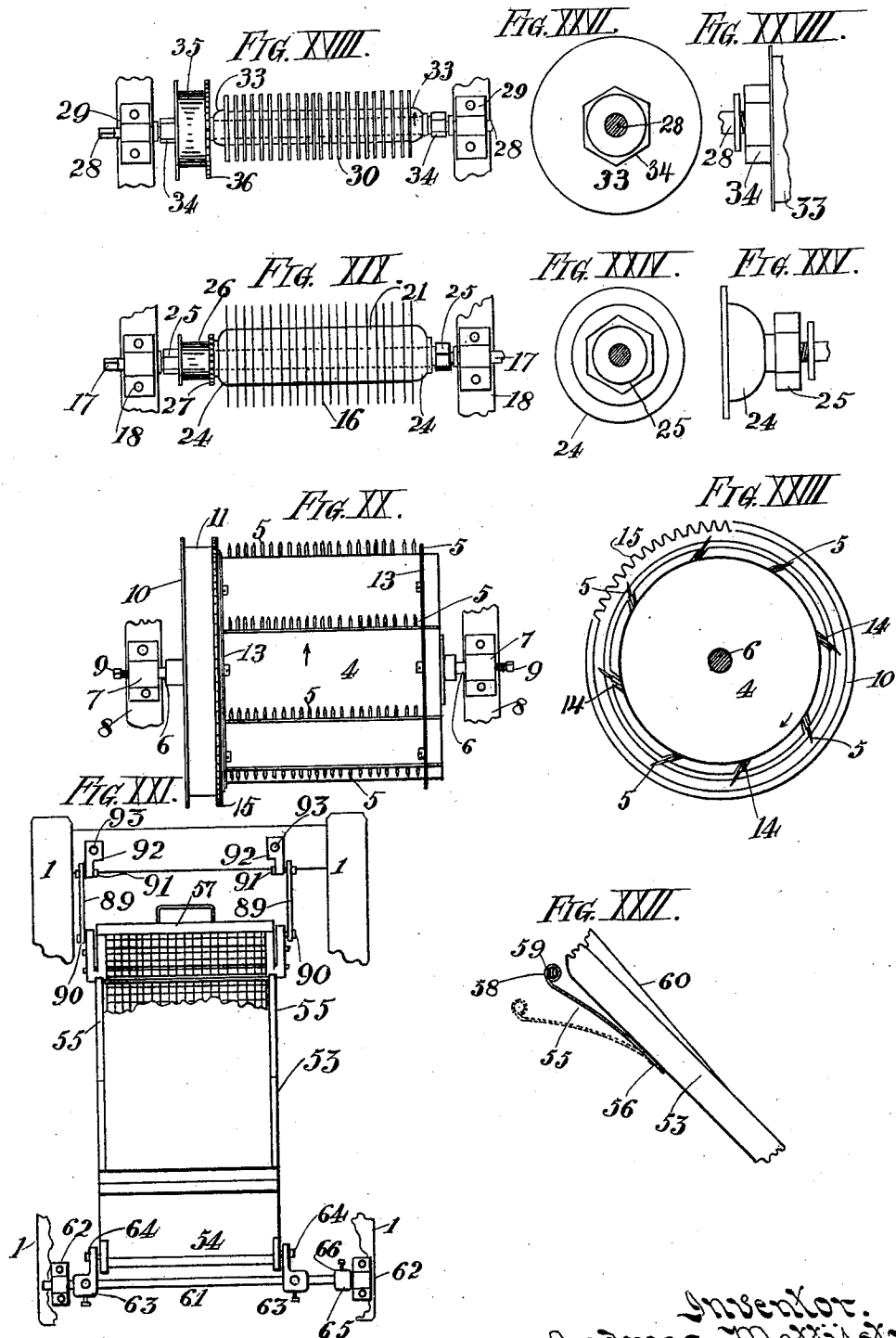

Witnesses:  
 Robt. Train.  
 A. M. Hagner

by

Inventor.  
 Andreas Mattijetz.  
 Knight Brev.  
 Attorneys:

(No Model.)

5 Sheets—Sheet 5.

A. MATTIJETZ.  
FEED CUTTER.

No. 602,345.

Patented Apr. 12, 1898.

FIG. XXVIII.

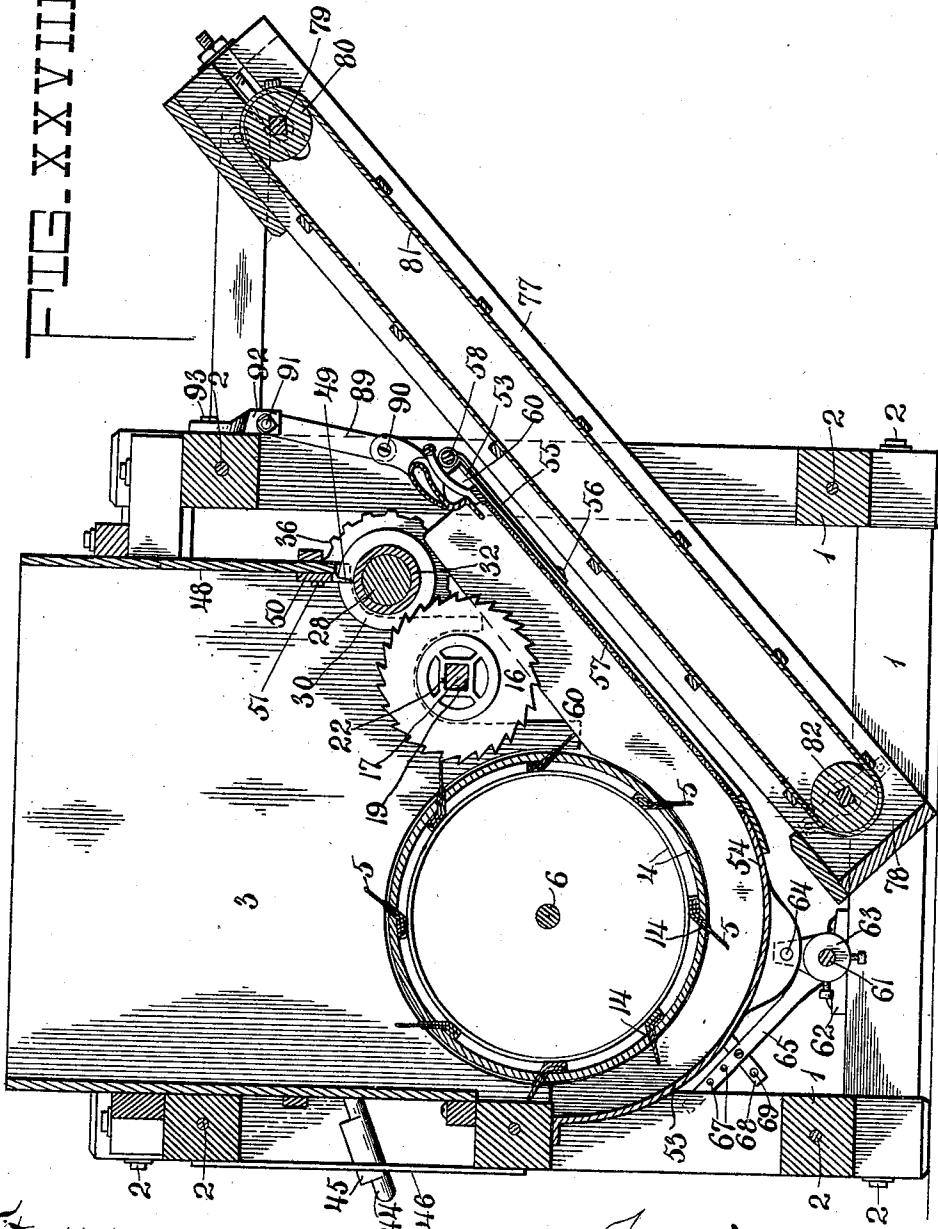

Witnessed.  
W. E. Allen  
W. Allen

Inventor.  
Andreas Mattijetz.  
By Knights  
Attys.

# UNITED STATES PATENT OFFICE.

ANDREAS MATTIJETZ, OF LOS ANGELES, CALIFORNIA.

## FEED-CUTTER.

SPECIFICATION forming part of Letters Patent No. 602,345, dated April 12, 1898.

Application filed August 11, 1897. Serial No. 647,875. (No model.)

*To all whom it may concern:*

Be it known that I, ANDREAS MATTIJETZ, a citizen of the United States, residing at Los Angeles, in the county of Los Angeles and State of California, have invented certain new and useful Improvements in Feed-Cutters, of which the following is a full, clear, and exact description, reference being had to the accompanying drawings, which form a part of this specification.

My invention relates to an improved device or machine for cutting hay or other coarse feed into fine particles for the purpose of feeding or other uses; and my invention consists in certain features of novelty hereinafter described and claimed.

Figure I represents a front elevation of my improved machine. Fig. II is a rear elevation thereof. Fig. III is a front elevation of the rear section of the hopper, showing comb for stopping the feed. Fig. IV is an enlarged side elevation of one of the saws for cutting the feed. Fig. V is a side elevation showing means for tightening the operating-belt. Fig. VI is a side elevation taken on the opposite side from Fig. V. Fig. VII is a plan view of one of the screens through which the finely-cut feed passes. Fig. VIII represents a side elevation and edge view of the washers interposed between the cutting-saws. Fig. IX is a side elevation and edge view of a slightly different form of washer used for the same purpose as that shown in Fig. VIII. Fig. X is a side elevation of one of the disks, of which there are a series and between which the outer periphery of the saws operate. Fig. XI is a side and edge elevation of one of the disks mentioned in describing Fig. X, showing collars on the disk for spacing them apart. Fig. XII represents a bottom view of the machine. Fig. XIII represents a top view thereof. Fig. XIV represents a side elevation of the adjustable lever for tightening the belt. Fig. XV is a bottom view of the adjustable lever. Fig. XVI is an enlarged detail view showing a series of the disks between which the saws operate and a fragment of the hopper with comb attached thereto. Fig. XVII is an enlarged detail view showing portions of the feed-drum, the cutting-saws, and the disks between which the saws operate. Fig. XVIII is a detail view showing shaft with series of disks mounted

thereon. Fig. XIX is a detail view showing shaft with cutting-saws mounted thereon. Fig. XX is a detail view showing feed-drum with teeth attached thereto. Fig. XXI is a bottom view of sieve-frame, showing sieve in position. Fig. XXII is a detail side elevation of sieve-frame, showing adjustable spring for holding the sieve. Fig. XXIII is an end elevation of feed-drum, showing sprocket-teeth thereon by which it may be operated. Fig. XXIV is an end view showing movable head by which the cutting-saws are clamped in position on their shaft. Fig. XXV is a side elevation of adjustable head for clamping the cutting-saws. Fig. XXVI is an end view of adjustable head for clamping the disks on the shaft and between which the saws operate. Fig. XXVII is an enlarged side elevation of the adjustable head for clamping the disks upon the shaft. Fig. XXVIII is a vertical longitudinal section of the machine.

Referring to the drawings, 1 represents the supporting-frame, having suitable cross-rods 2 extending from side to side of the machine for holding the frame together.

3 represents the hopper, into which the feed is placed in order to cut it into fine particles.

4 represents the feed-drum, having series of teeth 5 secured at intervals around its periphery in order to carry the feed to the cutting-saws. The drum 4 is mounted upon a shaft 6 and operates in boxes 7, supported by a stepped frame 8, said stepped frame being secured to and supported by the frame 1. The drum 4 is made adjustable laterally by means of set-screws 9, operating in the boxes 7, the inner ends of which bear against the ends of the shafts 6, whereby by the adjusting of said set-screws the drum may be moved laterally to adjust the teeth 5 to the cutting-saws between which they pass.

10 represents a pulley on the end of the drum, having a groove 11, in which the band 12 may operate to rotate the drum.

13 represents disks secured to the drum 4 at the outer ends of the rows of teeth 5, said disks fitting flush against the sides of the hopper and preventing the passage of the finely-cut feed or other foreign matter between the edges of the drum and the sides of the hopper. The drum is provided with a series of peripheral tangential openings or slots 14,

into which the rows of teeth 5 are set and from which they may be removed when desired for the purpose of renewal or repair. The drum 4 is also provided on the disk 13 with sprocket-teeth 15, by which means, if desired, the drum may be driven by a sprocket-chain instead of by the band 12.

16 represents the cutting-saws, mounted on a shaft 17, journaled in boxes 18, and supported on one of the steps of the frame 8. The central portion of the shaft 17 is made square, as shown at 19, and the saws 16 are provided with a central square aperture 20, so that when the saws have been located upon the square shaft it is impossible for them to turn without the shaft turning. Interposed between each of the saws 16 and located on the shaft 17 are a series of washers 21, having a square central opening 22 to fit the squared portion of the shaft 17. In Fig. IX I have shown a slightly-different form of washer which may be made of metal, its construction being formed of open-work, as shown at 23, in order to lighten it and save material. After placing the saws and the intervening washers upon the shaft 17 I secure the saws in position by means of adjustable heads 24, located on the shaft 17 on the outside of the outer saw, said heads being clamped against the saw by means of jam-nuts 25.

26 represents a pulley on the shaft 17 with which the belt 12 engages in order to revolve the shaft 17 and operate the saws to cut the feed. This pulley is provided at one of its ends with sprocket-teeth 27, whereby a sprocket-chain may be used in place of the belt 12, if so desired.

28 represents a shaft mounted on a still higher step of the frame 8, journaled in boxes 29 and having a series of smooth disks 30 thereon, said disks being provided with a central circular aperture 31 in order to permit their being moved along the shaft. The disks 30 are provided with collars 32, said collars having their periphery of less diameter than the main body of the disks, the object of said collars being to space the disks apart, so that the outer periphery of the saws 16 may pass between the outer periphery of the disks. (See Fig. XVII.)

33 represents heads located on the shaft outside of the outer disks, said heads serving to clamp the disks in position.

34 represents jam-nuts mounted on the shaft 28 for forcing the heads 33 in contact with the disks.

35 represents a pulley having a central groove in which the belt 12 operates, said pulley also having sprocket-teeth 36, with which a sprocket-chain may be connected in order to drive the disks in place of the belt 12. As the feed-drum rotates the feed is forced into the hopper, falls upon the same, and is carried by the teeth 5 to the saws 16, the teeth 5 operating between the saws. The saws catch the feed from the teeth, cutting it into fine particles, the opposite sides of the

saws passing between the disks 30, said disks forming a resistance to any feed not properly cut and holding the same until the saws have performed their functions in cutting the feed. In order to keep the belt in a taut condition, I provide a lever 37, pivoted at 38 to a hanger 39, said hanger being secured at 40 to the frame 1. The lever 37 is provided on one of its ends with an approximately triangular-shaped head 41, in which are journaled two rollers 42 43. The belt 12 in passing over the pulley 10 and pulleys 26 35 for operating the drum, saws, and disks, between which the saws operate, is held taut by means of the rollers 42 43 on the lever 37, as said belt extends over the pulleys, the lever 37 being adjusted at will by having its outer end 44 moved either up or down, said lever having a catch 45 thereon which engages a rack 46, by which means the lever may be held at any desired position, and by loosening the lever 37 the drum and saws may be at once stopped in their revolution, the loosened belt slipping upon the pulley and roller. The roller 42 is provided on one of its ends with sprocket-teeth 47, so that when a sprocket-chain is used in place of the belt 12 it may be run over said roller 42 and kept taut in the same manner as the belt 12.

48 represents a rear board of the hopper, said board having teeth 49, secured to its lower end by means of a strip 50 and bolts 51, the purpose of said teeth being to extend down between the disks 30 and prevent the passage of feed from the rear end of the hopper, (see Fig. XVI,) said board being removable and having suitable brackets 52 thereon, by which means it may be suitably secured to the sides of the hopper.

53 represents a sieve-frame extending beneath the hopper and having its lower end 54 made in the form of a cradle to conform with the shape of the feed-drum 4, said cradle being adapted to receive the material too coarse to pass through the sieve and retaining said material until the teeth of the drum pick it up and carry it around to be again thrown upon the saws and further reduced in size. The sieve-frame 53 is provided with a spring 55, having one of its ends secured at 56 to the under side of the frame and its outer end free to be depressed in order to admit the sieve 57. The spring proper for holding the sieve is composed of two members secured to the under side of the bars forming the respective sides of the sieve-frame, said members being connected by a cross-rod 58, the ends of the spring being coiled around said rod and turned up, as shown at 59, in order to retain the sieve in position.

60 represents a flaring projection of the sieve-frame, which extends up on the sides of the hopper to prevent the escape of the cut feed from the sides of the sieve-frame.

61 represents a transverse shaft supported in boxes 62, said boxes resting upon the frame 1. To the shaft 61 I adjustably secure

brackets 63, the upper ends of said brackets being pivoted at 64 to the sides of the cradle 54.

65 represents an arm having its lower end adjustably pivoted at 66 to one end of the shaft 61. The arm 65 is provided with a series of holes 67, with which the shaker-rod 68, having a like series of holes 69, may be adjustably secured. The opposite end of the shaker-rod 68 is pivoted at 70 to a wheel or disk 71, said wheel or disk being secured on the end of the shaft 17 on which the cutting-saws are located. Thus as the saw and shaft are driven the wheel 71 is rotated, and the shaker-rod 68 will cause the arm 65 to move back and forth, thus giving a vibratory motion of the cradle 54 and sieve-frame 53. If it is desired to change the stroke of the shaker-arm 68 other than by the adjustable means shown, the wheel 71 may be transferred to the shaft 28, upon which the disks 30 are mounted, said shaker-rod being provided with a hole 72 into which the pin 73 may be inserted in securing it to the wheel 71 when the wheel has been placed upon the shaft 28. 74 represents the pulley on the opposite end of the saw-shaft 17, to which a belt 75 may be attached when the machine is operated by power.

76 represents a crank placed upon the end of the shaft 28, which may be used when the machine is operated by hand-power.

77 represents a straw or feed elevator having its lower end secured to the frame 1 at 78, and having a shaft 79 at its upper end on which is mounted a suitable roller 80, over which an endless belt or carrier 81 travels.

82 represents a roller at the lower end of the carrier, around which the endless belt travels.

83 represents a pulley on one end of the shaft 79, said pulley being connected with a pulley 84 on the shaft 28 by means of a driving-belt 85.

86 represents an arm pivoted to the frame 1 at 87 and having a grooved roller 88 on its lower end, said roller resting on the belt 59 to take up any slack therein. The upper end of the sieve-frame 53 is supported by hangers 89, said hangers having their inner ends pivoted at 90 to the sieve-frame and their outer ends pivoted at 91 to brackets 92, said brackets being secured at 93 to the frame 1.

I claim as my invention—

1. The combination of a supporting-frame, a hopper, a stepped frame, a feed-drum having rows of teeth at intervals around its periphery and a shaft journaled on the lowest step of the stepped frame, the circular saws having a shaft journaled on the intermediate step of the stepped frame, the disks having a shaft journaled on the highest step of the stepped frame, and means whereby the shafts are operated; substantially as described.

2. The combination of a supporting-frame,

a hopper, a stepped frame, a feed-drum having rows of teeth and a shaft provided with a pulley and journaled on the lowest step of the stepped frame, the circular saws having a shaft provided with a pulley and journaled on the intermediate step of the stepped frame, the disks having a shaft provided with a pulley and journaled on the highest step of the stepped frame, the hanger secured to the supporting-frame, the lever having a head and pivoted to the hanger, the paired rollers mounted in the head of the lever, and the driving-belt working around the pulleys and over the rollers; substantially as described.

3. The combination of a supporting-frame, a hopper, a stepped frame, a feed-drum having rows of teeth and a shaft provided with a pulley and journaled on the lowest step of the stepped frame, the circular saws having a shaft provided with a pulley and journaled on the intermediate step of the stepped frame, the disks having a shaft provided with a pulley and journaled on the highest step of the stepped frame, the hanger secured to the supporting-frame, the vertical rack-bar secured to the supporting-frame, the lever having a head at one end and a catch engaging the rack-bar at the other end, and pivoted to the hanger, the paired rollers mounted in the head of the lever, and the driving-belt working around the pulleys and over the rollers; substantially as described.

4. The combination of a supporting-frame, a stepped frame, a feed-drum having rows of teeth at intervals around its periphery and a shaft journaled on the lowest step of the stepped frame, the circular saws having a shaft journaled on the intermediate step of the stepped frame, the disks having a shaft journaled on the highest step of the stepped frame, a hopper having a rear board provided with teeth fitting between the disks, and means whereby the shafts are operated; substantially as described.

5. The combination of a supporting-frame, a hopper, a stepped frame, a feed-drum having rows of teeth at intervals around its periphery and a shaft journaled on the lowest step of the stepped frame, the circular saws having a shaft journaled on the intermediate step of the stepped frame, the disks having a shaft journaled on the highest step of the stepped frame, a sieve-frame extending beneath the hopper and having its lower end in the form of a cradle, the sieve; means whereby the shafts are operated and means for vibrating the sieve-frame; substantially as described.

ANDREAS MATTIJETZ.

Witnesses:

J. W. KEMP,  
JAS. E. KNIGHT.